

MUS2-Tungsten Carbide



The MUS2 secondary cleaner is unique within itself to have a parallelogram designed into the cushion allowing constant blade angle attacking to the material flow, this allows for automatic adjustability within the cleaner for when the belt thickness can vary. The MUS2 is well suited for conveyor belts with mechanical fasteners when the (TI) tungsten impact blade is applied. For Vulcanised belt MATO recommend the (TL) tungsten long-life blade

MUS3-Tungsten Carbide



The MUS3 cleaner is designed to fit in small and restricted conveyor areas where limited space is available. With its low profile it is an excellent option for a tungsten carbide secondary belt cleaner. The MUS3 is also designed for reversing conveyor belts such as feeder belts or belts which have roll back. Suitable for conveyors with mechanical belt fasteners.

MUS3-Polyurethane



The MUS3 Polyurethane cleaner is a versatile cleaner, can be used as a water wiper or an alternative cleaner within any full system to enhance removal of any remaining material.

Installation of primary and secondary belt cleaners enhances the performance of any conveyor system.

- * Reducing the amount of carry back material
- * Reducing material spillage to minimize clean up work
- * Reducing the potential hazard of belt mis-tracking
- * Increase conveyor belt life
- * Increase production time due to excessive spillage
- * Protection against wearing components on the conveyor line

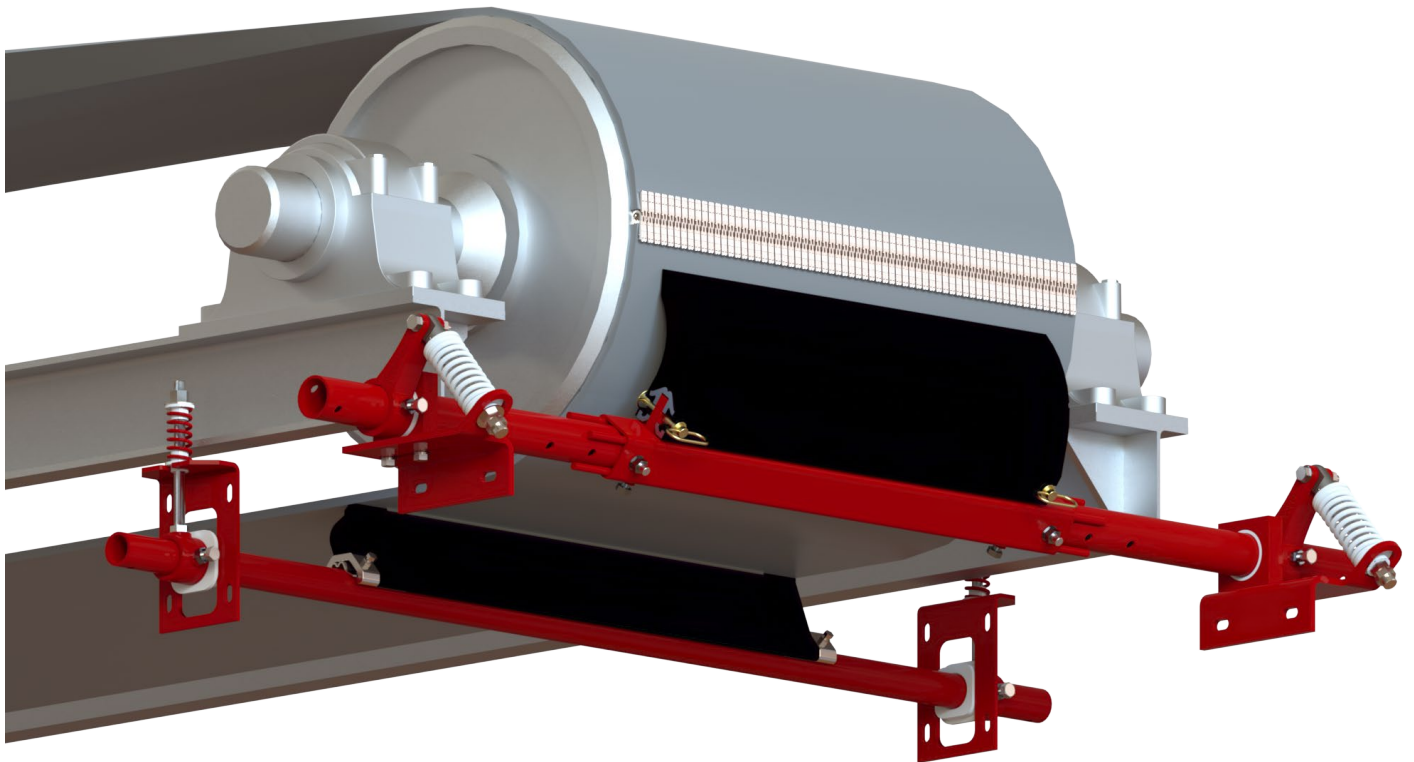

Type of Belt Cleaners

Primary Belt Cleaners

- * Tungsten Carbide for vulcanised conveyor systems
- * Polyurethane for conveyor systems with mechanical fasteners
- * Mounted on the head pulley of the conveyor system below the centre line out of the material flow for protection
- * Removes up to 95% of the fines material

Secondary Belt Cleaners

- * Tungsten Carbide for vulcanised conveyor systems
- * Specialised Tungsten Carbide for conveyor systems with mechanical fasteners
- * Mounted directly behind where the conveyor belt leaves the head pulley
- * Removes the sticky fine or wet material for when Primary Cleaners cannot be installed on the head pulley
- * Multiple secondary cleaners to be fitted on extreme applications

M-Trak segmented Blade Cleaners

The Unique range of all MATO MU M-Trak Cleaners are designed as a slide on and off system for quick and easy installation.

Tension Methods: CS - Compression Spring or AB - Air Bag Tension

Cleaner Type	MUS2	MUS3	MUS3
Blade Material	TC - Tungsten Carbide	TC - Tungsten Carbide	PU - Polyurethane
Blade Increments	150mm	150mm	150mm
Belt Speed	up to 5.0m/s	up to 5.0m/s	up to 3.5m/s
For Reversing Belts	No	Yes	Yes
Mechanical Fasteners	Yes	Yes	Yes



Cushion for the MUS2 and MUS3 are available in 45 and 65 duro hardness for optimum belts speeds.
The MUS3 PU blade has a hardness of 93a

Tungsten Carbide Segmented Blade Cleaners

The MC range of bolt-on secondary cleaners for customers who currently use equivalent products

Cleaner Type	MCS2	MCS3	MCS4	MCS5
Blade Material	TC - Tungsten Carbide	TC - Tungsten Carbide	TC - Tungsten Carbide	TC - Tungsten Carbide
Blade Increments	150mm	150mm	150mm	150mm
Belt Speed	up to 5.0m/s	up to 5.0m/s	up to 5.0m/s	up to 5.0m/s
For Reversing Belts	No	Yes	No	Yes
Mechanical Fasteners	No	Yes	Yes	Yes

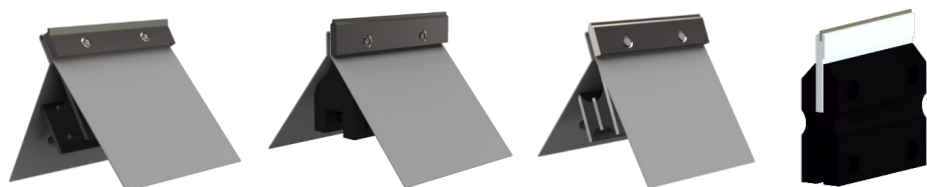

MATO Tungsten Carbide Secondary Belt Cleaner

- * MATO has designed specific grades of Tungsten Carbide Tips to work in most harsh conditions
- * TI - Tungsten Impact for harsh conditions and use on conveyors with mechanical fasteners
- * TL - Tungsten Long Life for vulcanised belts

Belt Width	Cleaned Width	Description	Part No.	kg
------------	---------------	-------------	----------	----

MUS3 POLYURETHANE CS BELT CLEANERS
Shaft Diameter 60.3mm

450mm	450mm	MUS3-PU-CS-450	81 204 72 01	25
600mm	600mm	MUS3-PU-CS-600	81 204 72 02	28
750mm	750mm	MUS3-PU-CS-750	81 204 72 03	32
900mm	900mm	MUS3-PU-CS-900	81 204 72 04	34
1050mm	1050mm	MUS3-PU-CS-1050	81 204 72 05	37
1200mm	1200mm	MUS3-PU-CS-1200	81 204 72 06	41

Shaft Diameter 73.0mm

1400mm	1350mm	MUS3-PU-CS-1400	81 204 72 07	46
1500mm	1500mm	MUS3-PU-CS-1500	81 204 72 08	51
1600mm	1500mm	MUS3-PU-CS-1600	81 204 72 09	57
1800mm	1800mm	MUS3-PU-CS-1800	81 204 72 10	65
2000mm	1950mm	MUS3-PU-CS-2000	81 204 72 11	73

The MUS3 Polyurethane cleaner is a versatile cleaner, can be used as a water wiper or an alternative cleaner within any full system to enhance removal of any remaining material.



MUS3 150mm PU blade, suitable for all applications, can be used as a water wiper or to remove wet sticky material



MUS3 SPECIFICATION:

- * Belts speeds up to 3.5M/sec
- * Blade Material Polyurethane 93a (PU)
- * Temperature -35°C to 85°C
- * Standard belt widths 450mm - 2000mm (alternative sizes available upon request)
- * Suitable for reversing conveyor belts
- * Suitable for mechanical belt fasteners

Belt Width	POS No:	Description	Part No.
------------	---------	-------------	----------

	1	MUS3 Polyurethane Blade 150mm	81 250 00 02
	2	MUS2,3 & 4 End Stop	81 240 00 07
	3	Nylon Guide Bush 60.3	81 235 60
	3	Nylon Guide Bush 76.1	81 235 76
	4	60.3 Adjusting arm, shaft Mount, inc bushes and lock nuts	81 315 60
	4	76.1 adjusting arm, shaft mount, inc bushes and lock nuts	81 315 76
	5	Red Spring suits (450mm - 1050mm)	81 312 21
	5	Silver Spring suits (1200mm - 2000mm)	81 314 22

The MUS3 Polyurethane cleaner is a versatile cleaner, can be used as a water wiper or an alternative cleaner

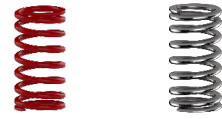

MUS3 Polyurethane Blade

Belt Width	Shaft Diameter 60.3mm		
------------	-----------------------	--	--

450mm	6	MUS Shaft suits 450mm	81 200 21 01
600mm	6	MUS Shaft suits 600mm	81 200 21 02
750mm	6	MUS Shaft suits 750mm	81 200 21 03
900mm	6	MUS shaft suits 900mm	81 200 21 04
1050mm	6	MUS Shaft suits 1050mm	81 200 21 05
1200mm	6	MUS Shaft suits 1200mm	81 200 21 06



Belt Width	Shaft Diameter 73.0mm		
------------	-----------------------	--	--

1400mm	6	MUS Shaft suits 1400mm	81 200 21 07
1500mm	6	MUS Shaft suits 1500mm	81 200 21 08
1600mm	6	MUS Shaft suits 1600mm	81 200 21 09
1800mm	6	MUS Shaft suits 1800mm	81 200 21 10
2000mm	6	MUS Shaft suits 2000mm	81 200 21 11

